

KSP-OC-1850MR-ER-X01 - Sphelar® One -

ver.5

Type

- Cell type Sphelar® cell
- Cells per module 1 cell
- ϕ 3 plastic mold

Features

- Low directivity
- Radial lead cells facilitate any serial and/or parallel connections.

Applications

- Active RFID Tags.
- Miniature Sensors.
- Minute electric power equipment.
- Educational kit etc.

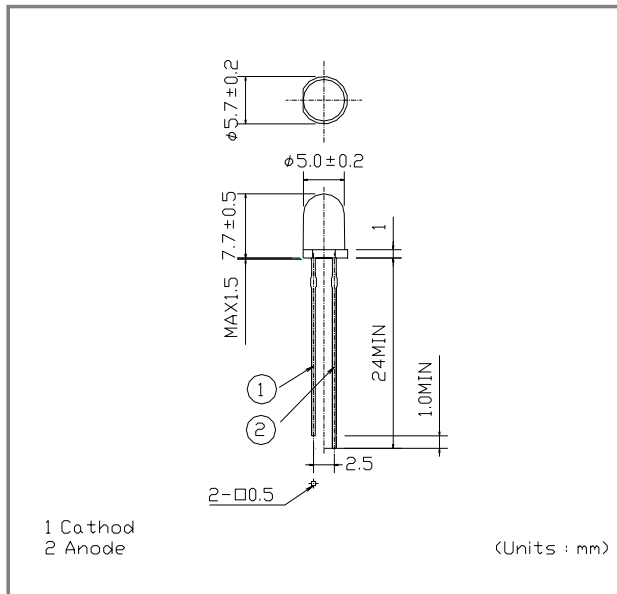
**Dimensions (unit: mm)****Absolute Maximum Ratings**

Parameter	Symbol	Value	Unit	Note
Reverse voltage	VR	5	V	
Storage temperature	Tstg	-20 to +80	°C	non condensing

Electrical performance under Standard Test Conditions(STC)

Item	Symbol	Min.	Tpy.	Max.	Unit	Test Conditions
Maximum Power	Pmax	-	0.66	-	mW	STC Irradiance 100mW/cm ² , AM1.5 spectrum, Ta=25°C
Maximum Power Current	Ipm	-	1.38	-	mA	
Maximum Power Voltage	Vpm	-	0.484	-	V	
Short Circuit Current	Isc	-	1.48	-	mA	
Open Circuit Voltage	Voc	-	0.589	-	V	

Remark

Specifications are subject to change without notice.

Contacts:

www.kyosemi.co.jp / info@kyosemi.co.jp

Kansai Sales Office: 949-2 Ebisu-cho, Fushimi-ku, Kyoto, 612-8201 Japan Tel: +81 75 605 7311 Fax: +81 75 605 7312 (Overseas Sales Dept.)

Tokyo Sales Office: 24th Sky Building, 2nd Floor, 1-34-3 Shinjuku, Shinjuku-ku, Tokyo 160-0022 Japan Tel: +81 3 5312 5360 Fax: +81 3 5312 5367

Eniwa Operation: 385-31 Toiso, Eniwa-shi, Hokkaido 061-1405 Japan Tel: +81 123 34 3111 Fax: +81 123 34 2110

Kyosemi Opto America Corp: 3003 Bunker Hill Lane, Suite 102, Santa Clara, CA 95054 USA Tel: +1 408 492 1486 Fax: +1 408 492 9843

Technical datasheet

Angular dependencies are shown.

(1)

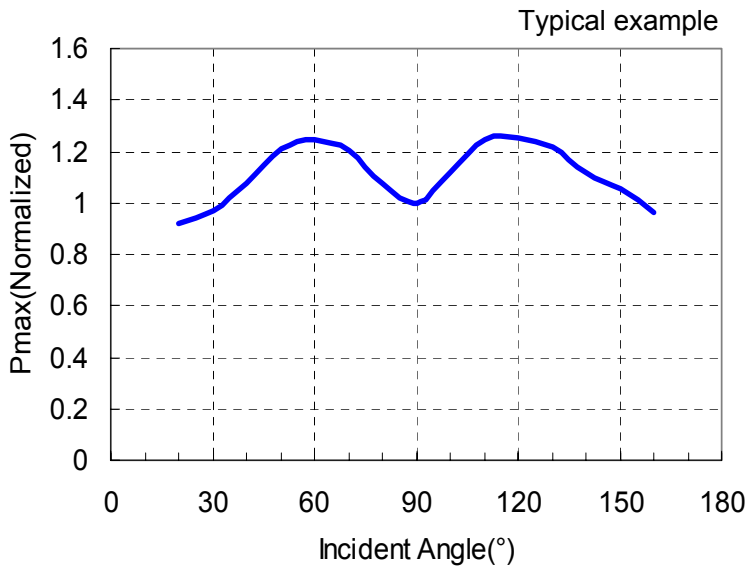
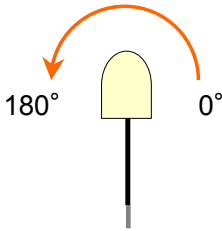

(2)

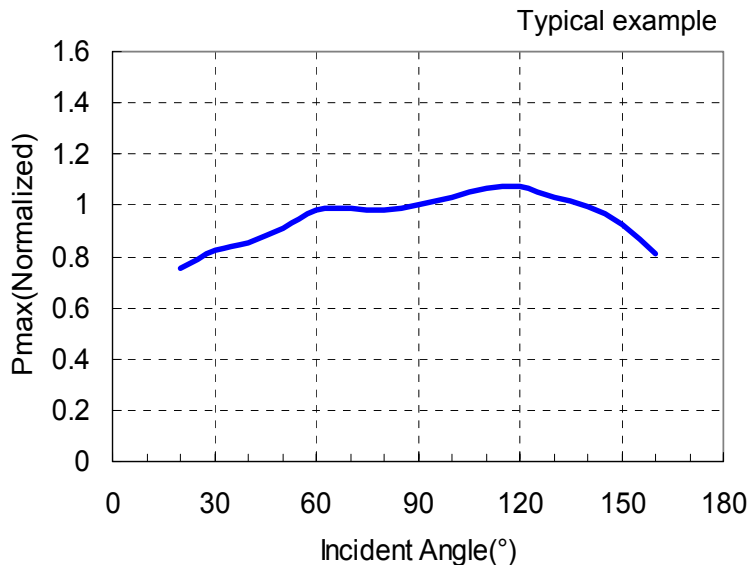
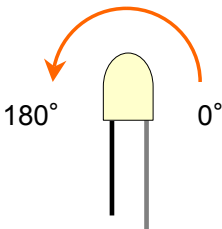

Conditions : AM1.5, 100mW/cm², 25°C

Specifications are subject to change without notice.